

# QUICK INSERT TOOLING

**THE IN-STOCK  
ALTERNATIVE.  
ORDER TODAY AND  
WORK TOMORROW.**

**SOLID AND  
LAMINATION TYPES**

**AVAILABLE IN  
FIVE SIZES**

**INSERT  
MATERIALS**

**FORTAL®**

**#3 STEEL**



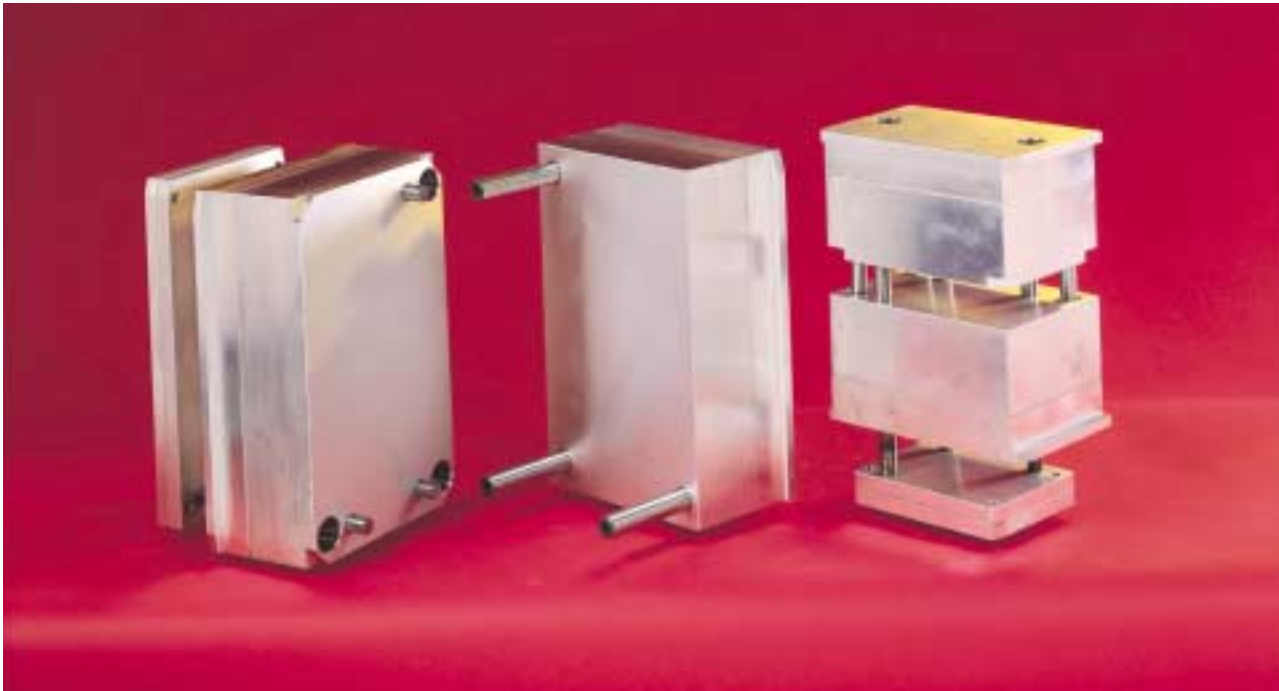

## UTILIZE SUPERIOR QUALITY TODAY!

### QUICK INSERT TOOLING -

**Faster Turnaround with Time and Costs Saving Advantages.**

Superior's Quick Inserts allow you to order today and work tomorrow. FORTAL® material construction machines 5 Times Faster than conventional mold steels.

Our Same Day Shipping program for 5 popular IN-STOCK insert sizes enables faster delivery to your customer. Order today and work tomorrow!

Superior's 3-pin design allows more consistent work area. Full length guide and return pins are furnished with all molds. Ejector / Pin plates are made of exclusive Fortal®, come pre-machined to accept provided socket head cap screws and return pins.

Quick Insert Tooling utilizes a 3-Pin design to expand the work area, and full length leader pins and shoulder bushings to provide a smooth operation.



Solid Type Quick Insert Tooling

Lamination Type Quick Insert Tooling

## THE IN-STOCK ALTERNATIVE

**ORDER TODAY AND WORK TOMORROW!**

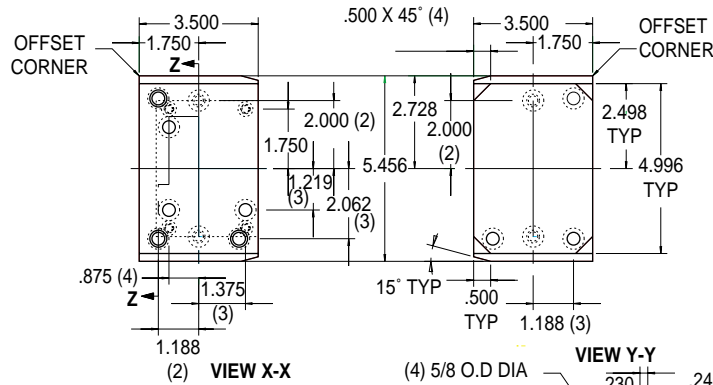

**LAMINATION TYPE**

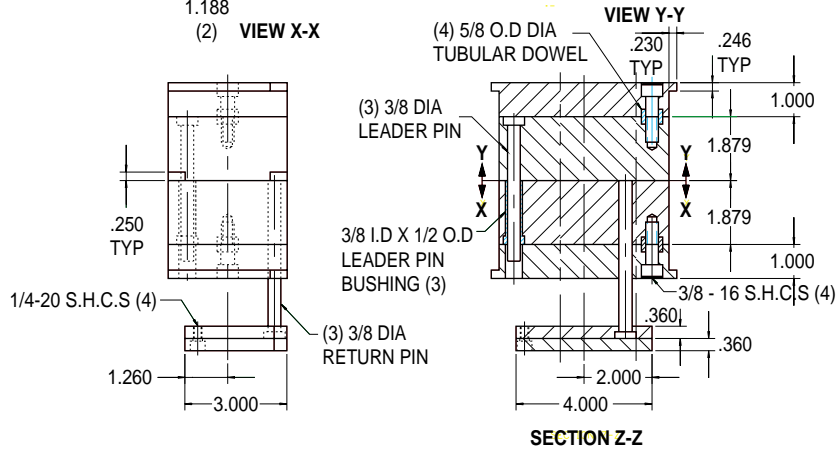

**SOLID TYPE**

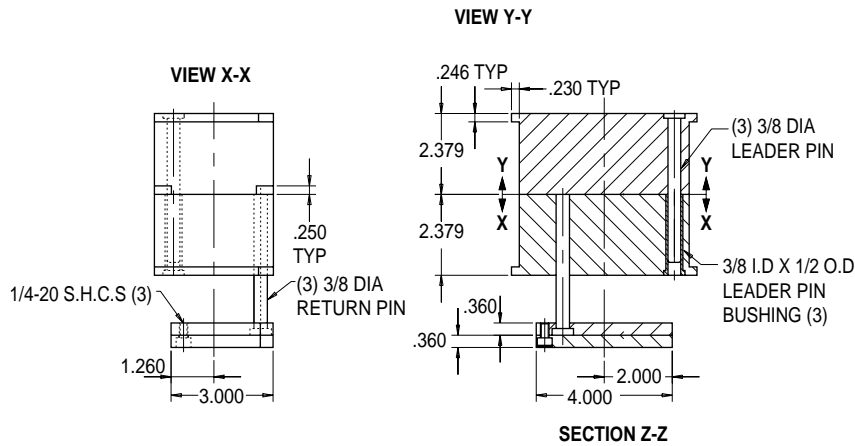

SIZE	TYPE	MATERIAL	PART NUMBER
3.5 X 5	Lamination	Fortal®	MH0809-17LF
3.5 X 5	Lamination	#3 Steel	MH0809-17LP
3.5 X 5	Solid	Fortal®	MH0809-23SF
3.5 X 5	Solid	#3 Steel	MH0809-23SP

When Ordering Please Specify:

1. Part Number
2. Quantity

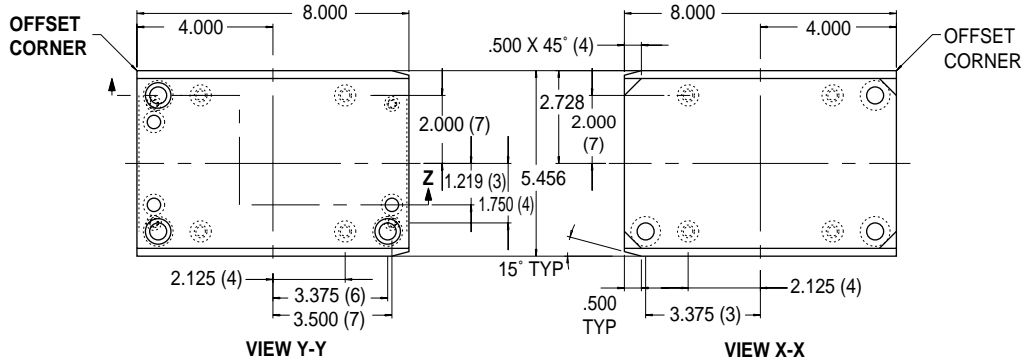

**LAMINATION TYPE**

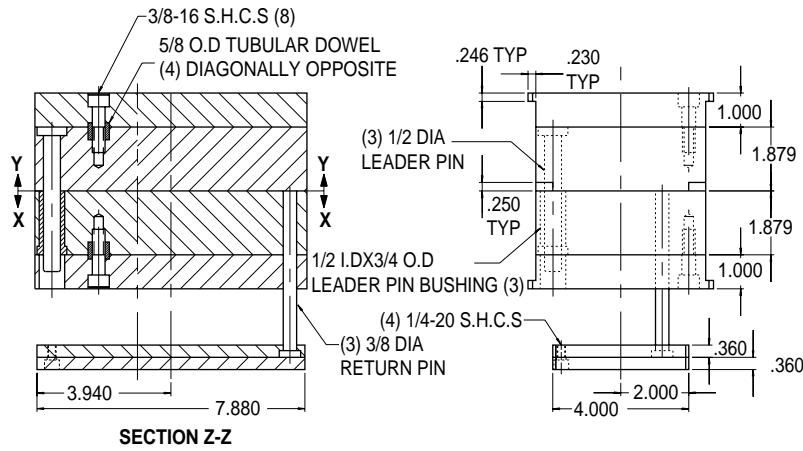

**SOLID TYPE**

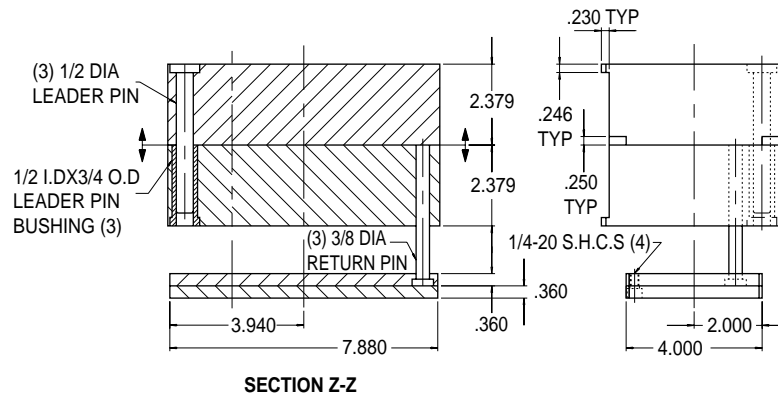

SIZE	TYPE	MATERIAL	PART NUMBER
5 X 8	Lamination	Fortal®	MU0809-17LF
5 X 8	Lamination	#3 Steel	MU0809-17LP
5 X 8	Solid	Fortal®	MU0809-23SF
5 X 8	Solid	#3 Steel	MU0809-23SP

**When Ordering Please Specify:**  
1. Part Number  
2. Quantity

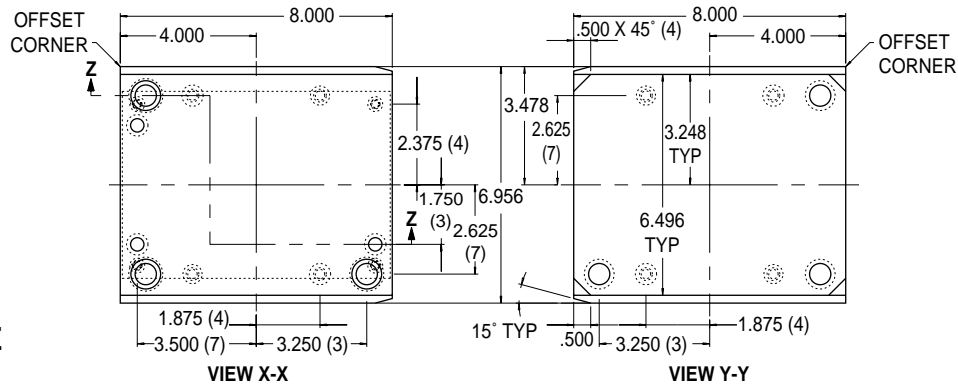

**LAMINATION TYPE**

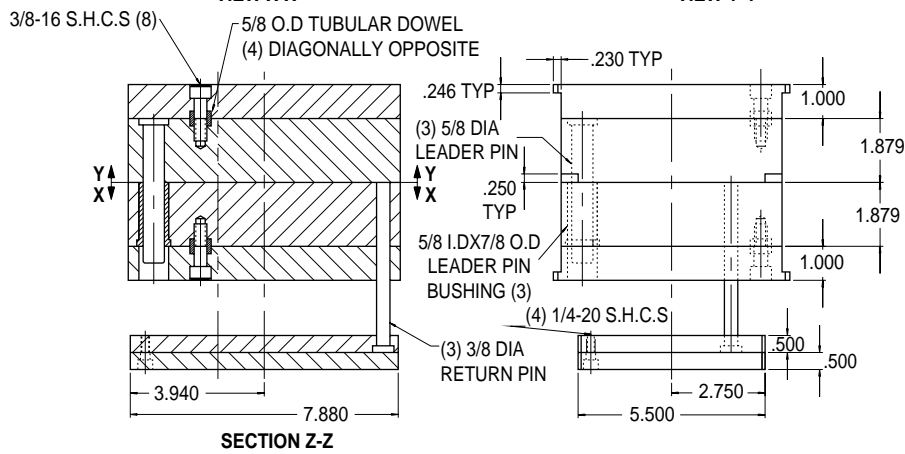

**SOLID TYPE**

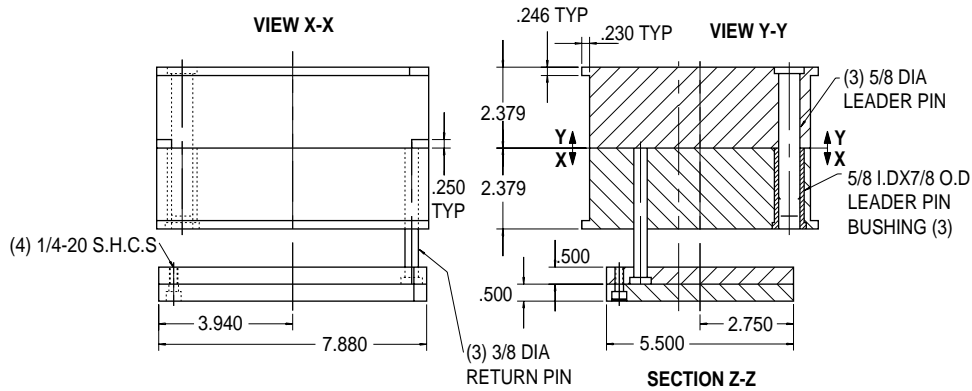

SIZE	TYPE	MATERIAL	PART NUMBER
6.5 X 8	Lamination	Fortal®	MU8490-17LF
6.5 X 8	Lamination	#3 Steel	MU8490-17LP
6.5 X 8	Solid	Fortal®	MU8490-23SF
6.5 X 8	Solid	#3 Steel	MU8490-23SP

When Ordering Please Specify:

1. Part Number
2. Quantity

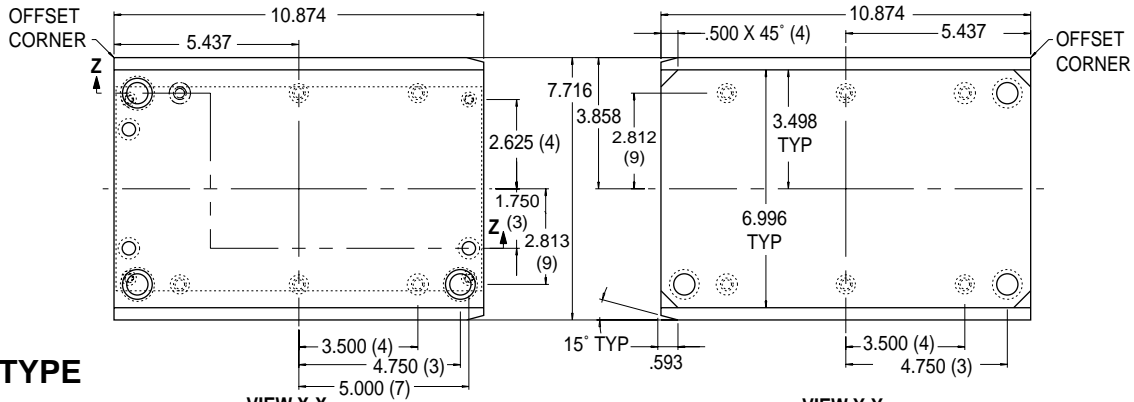

**LAMINATION TYPE**

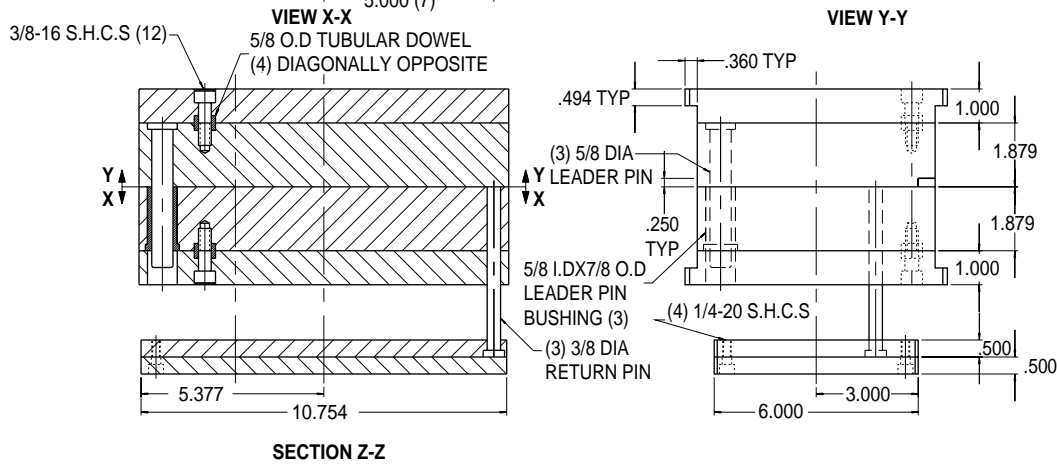

**SOLID TYPE**

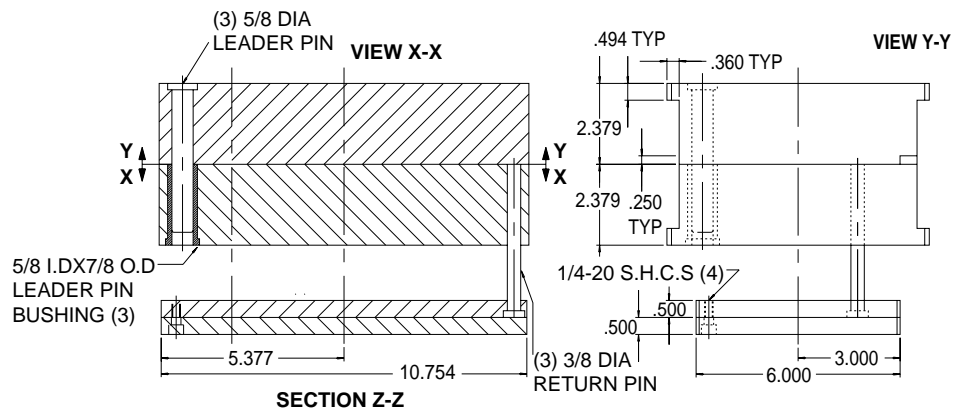

SIZE	TYPE	MATERIAL	PART NUMBER
7 X 11	Lamination	Fortal®	MU1012-17LF
7 X 11	Lamination	#3 Steel	MU1012-17LP
7 X 11	Solid	Fortal®	MU1012-23SF
7 X 11	Solid	#3 Steel	MU1012-23SP

**When Ordering Please Specify:**  
1. Part Number  
2. Quantity

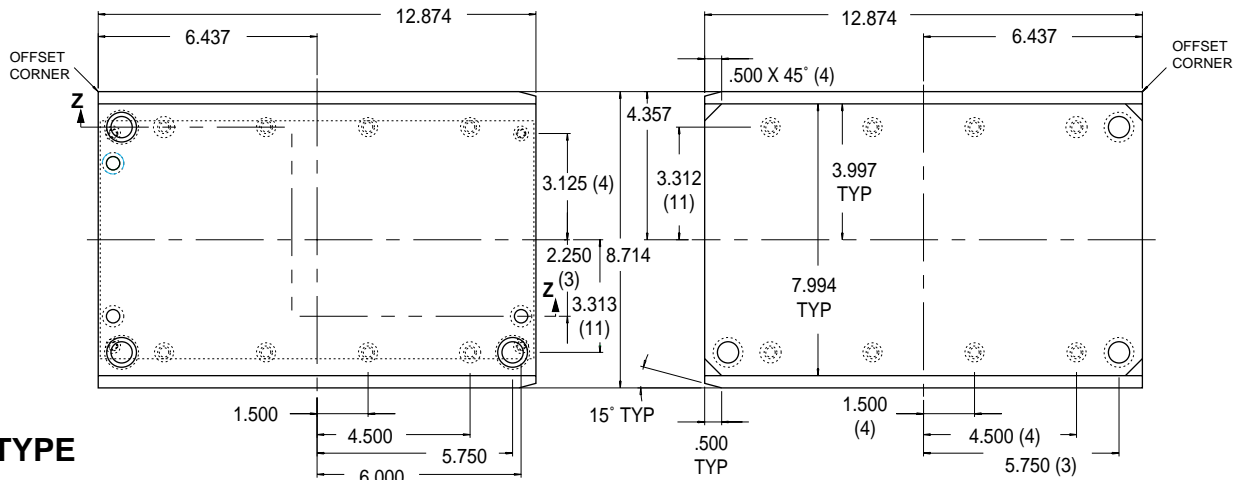

**LAMINATION TYPE**

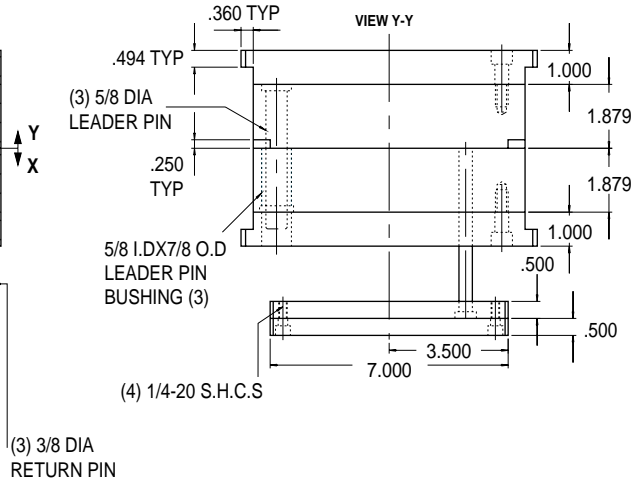
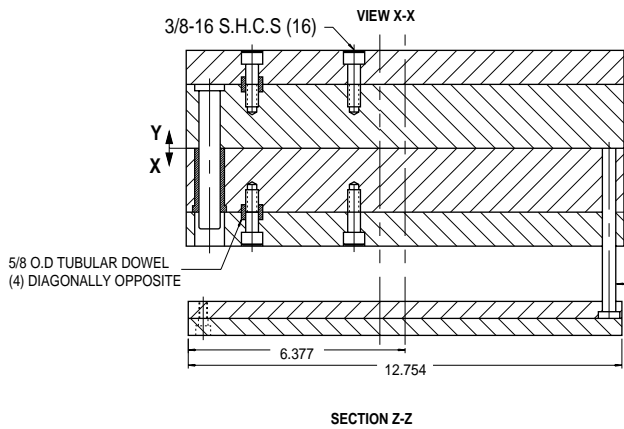

**SOLID TYPE**

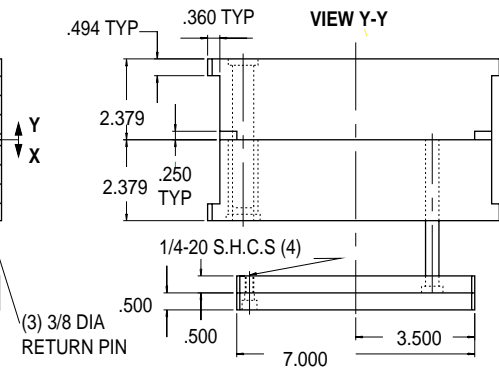
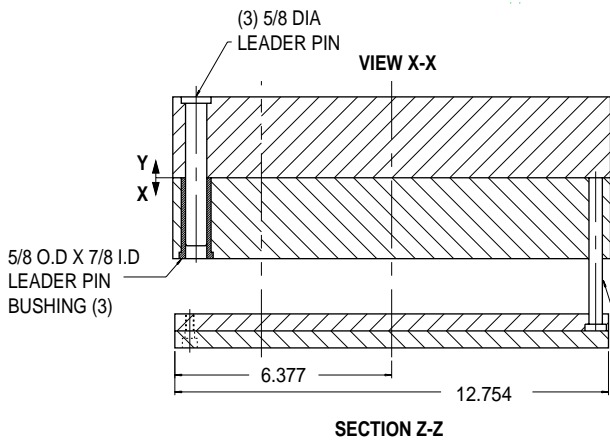

SIZE	TYPE	MATERIAL	PART NUMBER
8 X 13	Lamination	Fortal®	MU1214-17LF
8 X 13	Lamination	#3 Steel	MU1214-17LP
8 X 13	Solid	Fortal®	MU1214-23SF
8 X 13	Solid	#3 Steel	MU1214-23SP

**When Ordering Please Specify:**

1. Part Number
2. Quantity



**Cover all your bases with Cloz-It™**  
 Superior's new Cloz-It™ Ejector Housing Cover is the perfect addition to your mold base to help eliminate hazardous pinch points and debris jamming in your ejector housing. Its durable anodized aluminum design is exclusive to Superior and resists corrosion. And don't worry about covering your ejector operations. Cloz-It™'s convenient viewport ensures you will be able to monitor the ejector and return spring for proper operation.



*Each Cloz-It™ features an ejector viewport that shows ejector operating action and spring compression.*



*Cloz-It™ Ejector Housing Covers easily mount on most standard mold base widths.*



**The Perfect, Low-Profile Return Spring for Mold Bases with Cloz-It™ Installations**

Unlike ordinary die spring products, Superior's exclusive Return-Rite™ return springs are specially engineered to be smaller and more compact to take up less mold cavity area and not break through the plate edge. This reduces pinch points, debris jamming and gives the mold base an easy Cloz-It™ installation. Add a Cloz-It™ Ejector Housing Cover and you have a much safer and smaller mold base that costs less to operate and maintain.



**Space Saving:** *You can use standard mold bases with Return-Rite™ because the springs have small cavity area footprints. There is no need to relocate return pins or buy bigger mold bases any more.*

**Safe Operation:** *Compact Return-Rite™ springs eliminate sharp edges and do not break through the plate edge where accidents are more likely to occur.*



**SLIDE LOCK®**  
 Hold up to 8 lbs. per Slide-Lock without hydraulics or other complicated devices. Multiple Slide-Locks can be utilized to achieve greater weight retention. Simple, rugged design is virtually maintenance free. Superior Slide-Locks are recessed into slide for neat installation and can be retrofitted into your existing slides. Assembly made from quality materials and hardened for continuous production durability.



Standard and Custom Mold Bases.

Superior manufactures this and several other exclusive components as well as a full line of complete or rough finished mold bases and die sets. Call today for your free catalog or visit our web site at <http://www.superiordieset.com>

**Ask for our free CD-ROM Design Package!**

**With Superior you make the molds, we make the rest.**

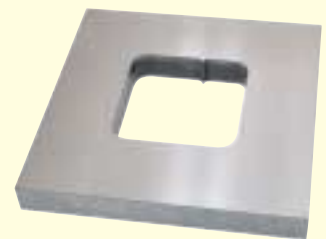

Torch Cut Pockets



Mold Plate, Rough, and Finished Machining Services



900 West Drexel Avenue  
 Oak Creek, WI 53154-0008

Local (414) 764-4900 • Toll Free (800) 558-6040  
 Fax (800) 657-0855

messages@supdie.com • Web [www.superiordieset.com](http://www.superiordieset.com)



Slide Lock™ and Other Mold Base Components